

## CNC Plasma Cutting Machine (2500x6000 mm) Brand: AMT, Model AMT 2500x6000 Made In Turkey (Brand new)

### UPL 2560 CNC Plasma Cutting Machine ( 2500x6000 mm )

- XPR 170 Hypertherm Power Source
- Hypertherm EDGE Connect TC
  - 19.5" industrial type screen
  - Hypertherm operator panel / Hypernet communication system
  - Remote connection interface / Phoenix Software
- Core Auto Gas Console
- Sensor THC Torch Height Control
- Hypertherm **Pronest Software included with True Hole Technology**
- 3 Axis (X,Y,Z)
  - 3 pieces AC servo motor and driver / 3 pieces planet type Neugart gear box
  - High accuracy linear rails / High accuracy an silent Atlanta Helis rack and pinion
- **Ethernet and Network Interfaces, USB Port**
- Plasma ignition consol
- Auto Cutting Height Correction Software
- Cutting table with **Pneumatic cutting area opening feature**
- Air Suction System with Cutting Table
- Moving control panel system

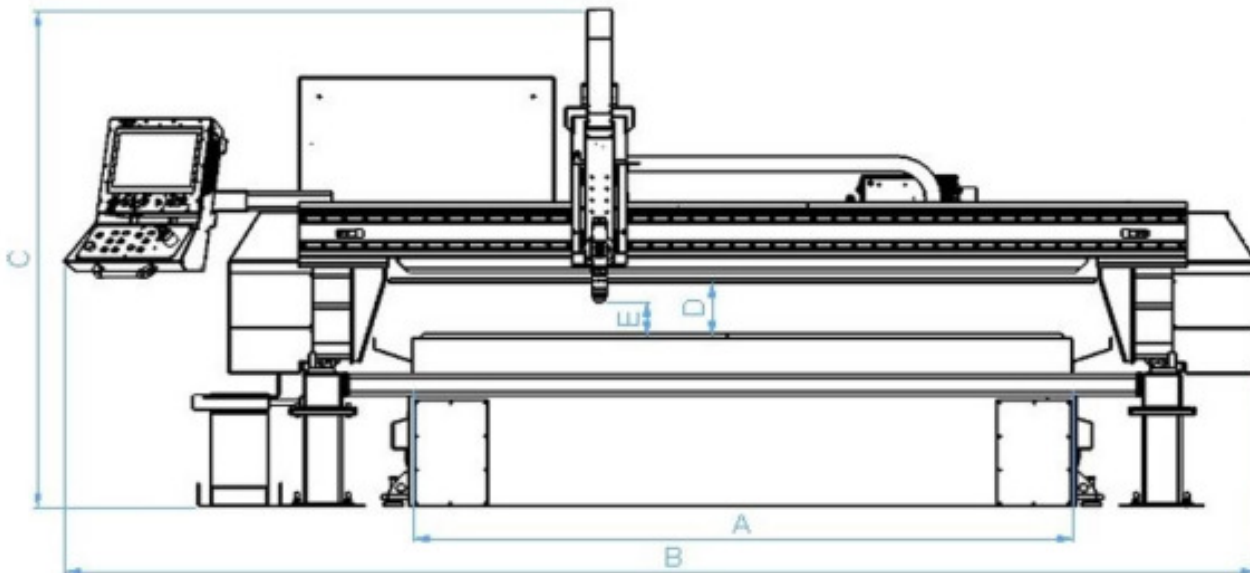

CUTTING WIDTH	A	mm	2540
TOTAL WIDTH	B	mm	4675
TOTAL HEIGHT	C	mm	2280
INTER GAP	D	mm	200
TORCH DISTANCE	E	mm	0 - 130
CUTTING LENGTH		mm	6096
TABLE HEIGHT		mm	762
SPEED		m/min	30
MACHINE AXIS		-	X , Y , Z
POSITIONING ACCURACY		mm	± 0,1 DIN 28206
REPITITION ACCURACY		mm	± 0,05 DIN 28206
CNC CONTROLLER			Hypertherm EdgeConnect TC
CAD/CAM SOFTWARE			Hypertherm Pronest
PLASMA CUTTING UNIT			Hypertherm XPR170
TORCH HEIGHT CONTROL			THC
MILD STEEL (MAX. CUTTING CAPACITY)		mm	1 - 60
MILD STEEL (PIERCE)		mm	1 - 35
STAINLESS STEEL (MAX. CUTTING CAPACITY)		mm	1 - 38
STAINLESS STEEL (PIERCE)		mm	1 - 22
ALIMINIUM (MAX. CUTTING CAPACITY)		mm	1 - 38
ALIMINIUM (PIERCE)		mm	1 - 25
CUT ANGLE CLASS		ISO 9013	2 - 3
GAS CONSOLE			CORE (Auto)
ENERGY			400V, 50Hz, 6bar air
WEIGHT		kg	7850
DUST COLLECTOR WEIGHT		kg	920