

CNC Lathe machine, Brand: AMT Model: AMT40, Made In China (Brand new)  
Controller: Fanuc OI TF System, Fanuc motor

### Technical parameter

Max. swing over bed:	450mm
Max. processing diameter:	400mm
Max. processing length:	500mm
Spindle taper A2-6	
Hydraulic hollow chuck, cylinder:	Standard 8"
Main motor KW 7.5/11	
Max spindle speed rpm 4500	
Diameter of the spindle:	66
Bar diameter:	50
X/Z axis screw size:	3210/3210
X axis limit travel:	250mm
X/Z axis motor torque:	N.M 11/15
X/Z axis linear guideway size:	35
Z axis limit travel:	530mm
Rapid feed of X/Z:	20000/20000 mm/min
X、Z connection type	Directed connection
Hydraulic turret	
Station	10 station
Center height:	80mm
Tailstock tip diameter:	72mm
Tailstock tip travel:	100mm
Tailstock max travel:	400mm
Tailstock sleeve taper	Mose 4
Positioning accuracy:	0.02mm
Repeated positioning accuracy:	0.01mm

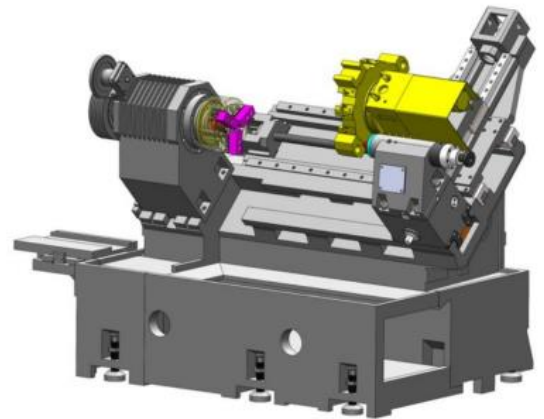

### Standard configuration:

China Hydraulic Hollow Chuck 8"  
Hydraulic turret 10 station  
Hydraulic tail stock  
Cooling system  
Auto lubrication  
Full protection  
Linear guide ways and ball screws  
Chain type chip conveyor, transformer.